

General Description

MECHANICAL

4. CYLINDER BLOCK

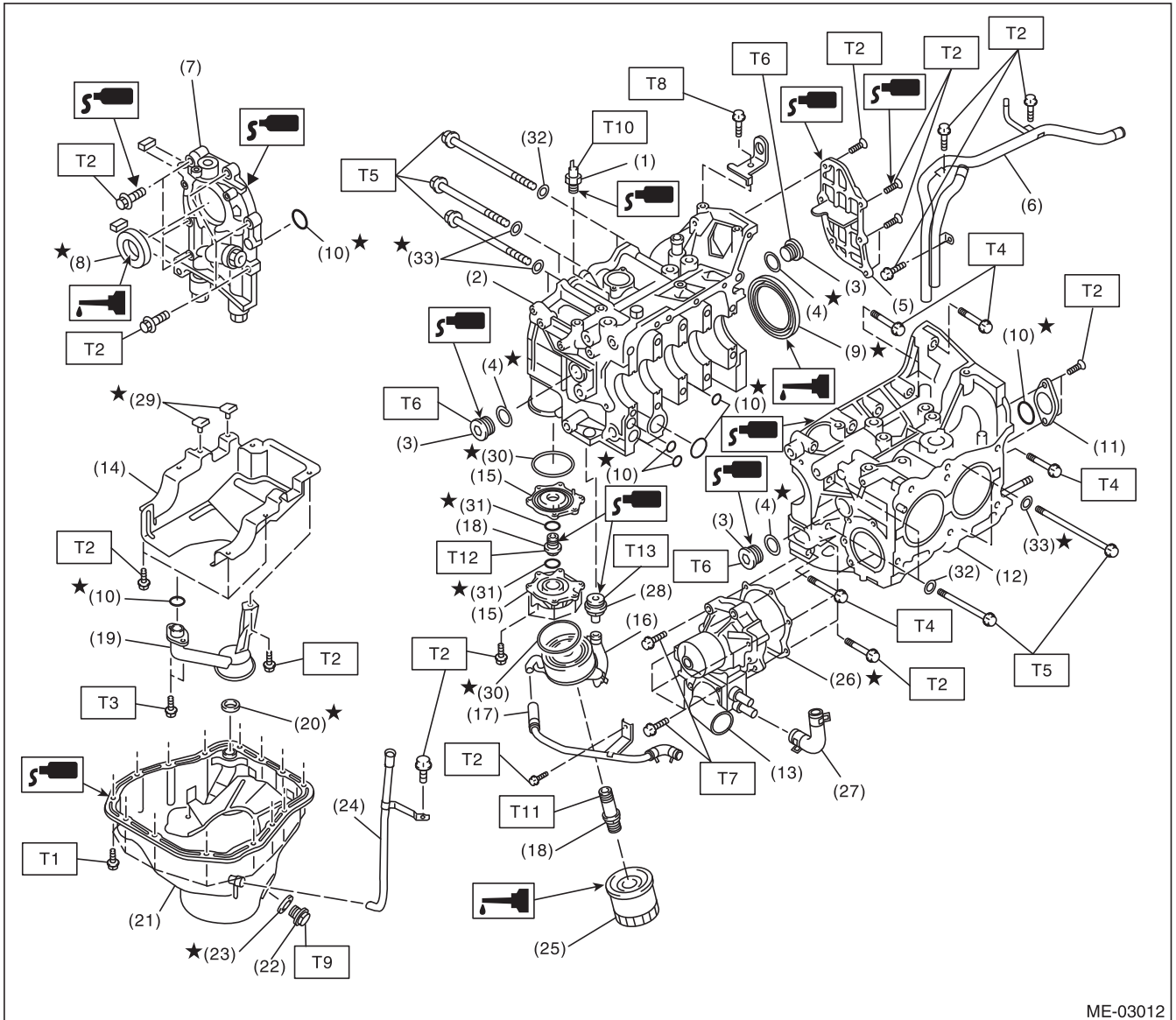

ME-03012

ME(H4DOTC)-10

General Description

MECHANICAL

(1) Oil pressure switch	(18) Connector	Tightening torque:N-m (kgf-m, ft-lb)
(2) Cylinder block (RH)	(19) Oil strainer	T1: 5 (0.5, 3.6)
(3) Service hole plug	(20) Gasket	T2: 6.4 (0.65, 4.7)
(4) Gasket	(21) Oil pan	T3: 10 (1.0, 7.2)
(5) Oil separator cover	(22) Drain plug	T4: 25 (2.5, 18.1)
(6) Water by-pass pipe	(23) Metal gasket	T5: <Ref. to ME(H4DOTC)-71, INSTALLATION, Cylinder Block.>
(7) Oil pump	(24) Oil level gauge guide	
(8) Front oil seal	(25) Oil filter	
(9) Rear oil seal	(26) Gasket	T6: 70 (7.1, 50.6)
(10) O-ring	(27) Water pump hose	T7: First 12 (1.2, 8.7) Second 12 (1.2, 8.7)
(11) Service hole cover	(28) Plug	
(12) Cylinder block (LH)	(29) Seal	T8: 16 (1.6, 11.6)
(13) Water pump	(30) Gasket	T9: 44 (4.5, 33)
(14) Baffle plate	(31) O-ring	T10: 25 (2.5, 18.1)
(15) Adapter	(32) Washer	T11: 54 (5.3, 39)
(16) Oil cooler	(33) Seal washer	T12: 45 (4.6, 33)
(17) Water by-pass pipe		T13: 69 (7.0, 50.9)
